



# ELECTRO-HYDRAULIC 2 POST LIFTS



**2.3T  
MAX**

**TL07**

**d m f**  
**(WAKEFIELD) LTD**

The Rotary TL07 Two Post Turf Lift provides safe, efficient access for servicing a wide range of turf equipment, supporting 3-wheel machines up to 1100kg and 4-wheel units up to 2300kg. Automatic wheel-engaging chocks ensure secure positioning, while overhead cable equalisation keeps the floor clear. Dual control panels allow easy operation from either side, and adjustable ramps and side rails accommodate wider vehicles. A wheel adapter kit also enables lifting of smaller-wheel equipment.

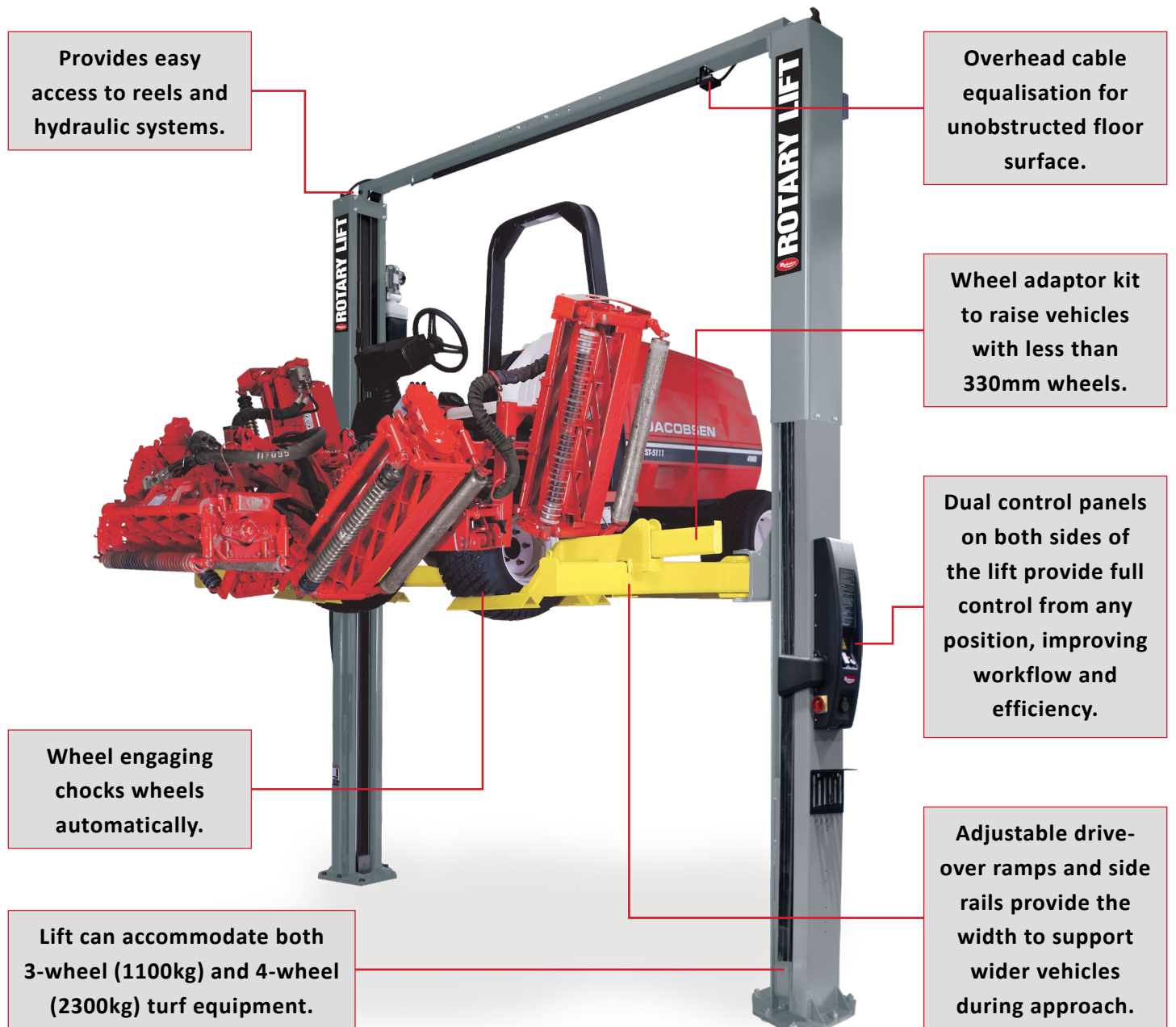

# TECHNICAL DATA:



Capacity	1100 - 2300kg
Number Of Columns	2
Column Layout	Symmetrical
Mode Of Drive	Electro Hydraulic
Control	Both Sides
Energy Kit	Standard
Installation Type	Surface Mounted
Maximum Lifting Height	1803mm
Lifting Time	45 Seconds
Lowering Time	40 Seconds
Cylinder Height Max Stroke	3778mm
Clear Span Between	2915mm
Drive Through Width	2324mm
Switchoff Level	4032mm
Minimum Ceiling Height	4200mm
Wheelbases Wheel Alignment	762 - 2235mm
Arm Layout	Asymmetrical
Driving Power	3 kW
Power Supply	230/400 V   50 Hz
Phases	3 Ph
Width	3496mm
Height	4166mm
Weight	980kg

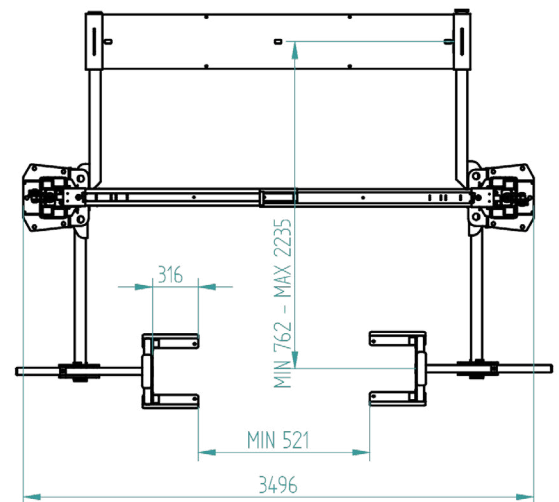
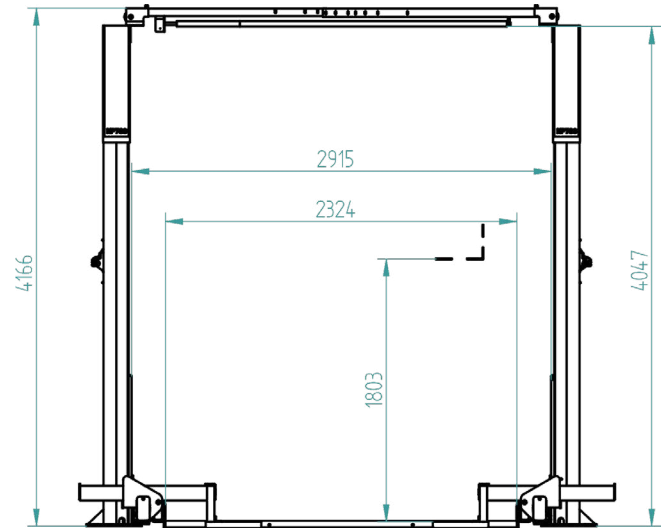

Technical changes reserved. Data are considered advertisement.





**THE ONE LIFT  
TO SERVICE THE ALL  
WITH AV ARMS**

**ALL  
VEHICLE  
ARM**

**dmf**  
(WAKEFIELD) LTD

Head Office: DMF Wakefield Ltd - 66 Wakefield Road, Ossett, Wakefield, WF5 9JS.



(01924) 370685



sales@dmfwakefield.co.uk



www.dmfwakefield.co.uk