

TTECHNIQUE

T3322 SERIES BATTERY LIFT



d m f
(WAKEFIELD) LTD

T3322 FEATURES

The unique TECHNIQUE T3322 series is equipped with an adjustable lifting platform to aid in disassembling vehicle battery packs, engines and transmissions.

- Ergonomic controls.
- Electro-hydraulic operation.
- Unidirectional high load bearing wheels with integrated brakes.
- Self-levelling load platform with specially shaped wood worktop.
- Powerful double hydraulic cylinder system.



CAPACITY
1.2T

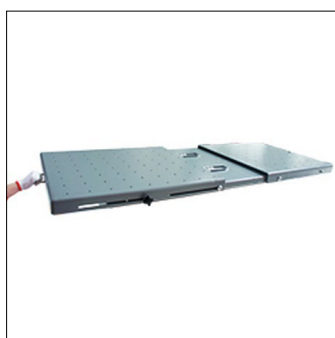

Extended platforms.



Reserved holes (100mm x 100mm)



Remote control.



Dual speed system.

T3322 TECHNICAL DETAILS

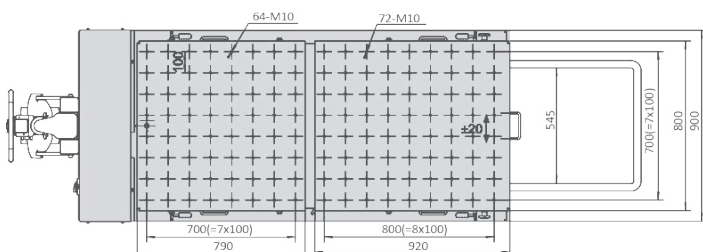
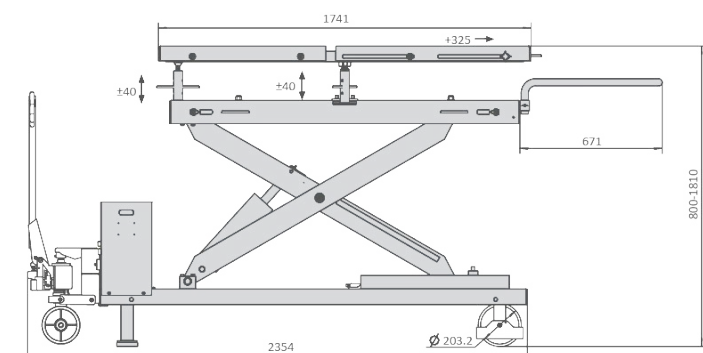

| | |
|-------------------------|----------------|
| Lifting Capacity | 1200kg |
| Max Height | 1810mm |
| Minimum Height | 800mm |
| Platform Length | 1741mm + 325mm |
| Platform Width | 800mm |
| Base To Floor Clearance | 196mm |
| Frequency | 50Hz |
| Voltage | 220v |
| Control Voltage | 24v |
| Full Stoke Time | 45 Seconds |

